

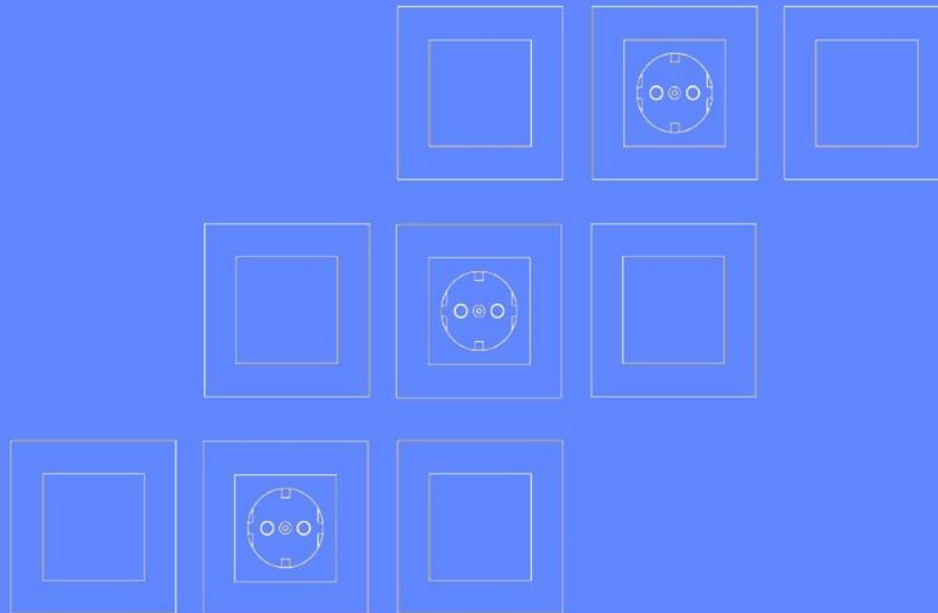

EFAPEL[®]

SOLUÇÕES ELÉTRICAS



EFAPEL®



EFAPEL®

efapel.com 1978

- Portuguese company established in 1978, located at Serpins (centre of Portugal);
- Biggest Portuguese company manufacturing electrical products for low voltage domestic installations (Wiring devices, Office Solutions, Electrical and Communications Distribution Pannels and Cable Trunkings systems);
- Leader of Wiring Devices and Cable Trunkings Portuguese market ($\approx 85\%$);
- Exports to more than 60 countries in 5 Continents:
Spain, France, Poland, Germany, Austria, Belgium, Holland,...
Iran, Russia, Saudi Arabia,
Chile, Colombia, Peru, United States,
Morocco, Tunisia, among others.
- Sports Sponsorships:
Football team (Académica de Coimbra OAF)
Cycling team (EFAPEL)



FROM PORTUGAL TO THE WORLD

EFAPEL[®] PORTUGAL

EFAPEL - Serpins
40° 9' 34" N
8° 12' 48" O

EFAPEL - Alto do Padrão
40° 6' 48" N
8° 17' 35" O



Costa Rica

Chile
Curacao
Peru
Suriname

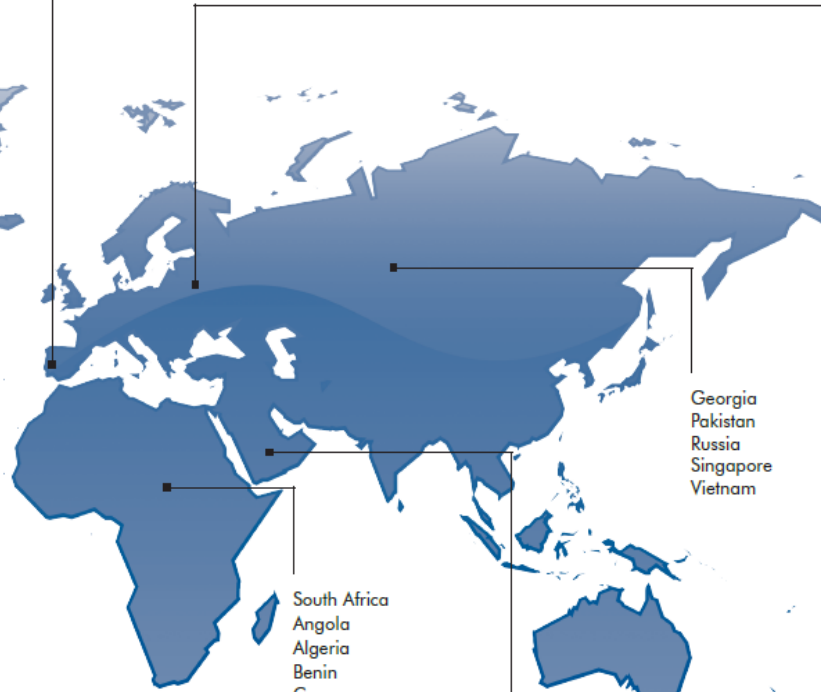

South Africa
Angola
Algeria
Benin
Cameroon
Ivory Coast
Morocco
Mozambique
São Tomé and Príncipe
Senegal
Tunisia

Saudi Arabia
United Arab Emirates
Iran
Jordan

Georgia
Pakistan
Russia
Singapore
Vietnam

Germany
Armenia
Austria
Belgium
Belarus
Bosnia and Herzegovina
Bulgaria
Cyprus
Croatia
Denmark
Spain
Estonia
France
Greece
Netherlands
Hungary
Italy
Latvia
Lithuania
Luxembourg
Poland
Czech Republic
Sweden
Turkey
Ukraine

Organisation

- Research & Development
- Production
- Quality control
- Sales & Marketing
- Support: Logistics
 Technical
 Commercial
 Promotional

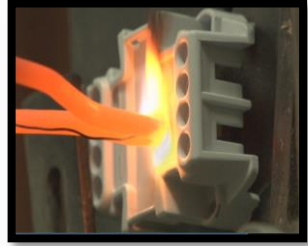
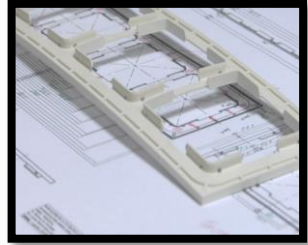
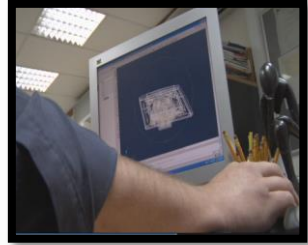

Certifications

Company..



APCER – Certification of **Quality Management System** **ISO 9001**

APCER – Certification of **Environmental Management System** **ISO 14001**

APCER – Certification of **Health and Safety in the Work System** **OHSAS - 18001**

Products

- CERTIF: **Portugal**
- VDE: **Germany**
- AFNOR - LCIE: **France**
- KEMA Quality B.V.: **The Netherlands**
- CEBEC: **Belgium**
- GOSSTANDART: **Russia**
- UKRSEPRO: **Ukraine**
- CE: **European Community Directives**
(CE - ROHS – REACH, etc)



EFAPEL®

Wiring Devices



LOGUS⁹⁰



EFAPEL®

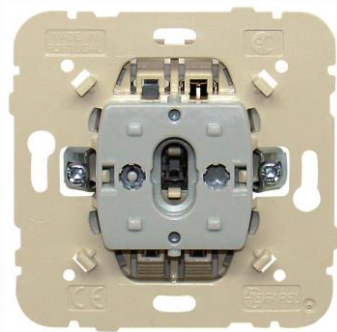

s é r i e
mec 21

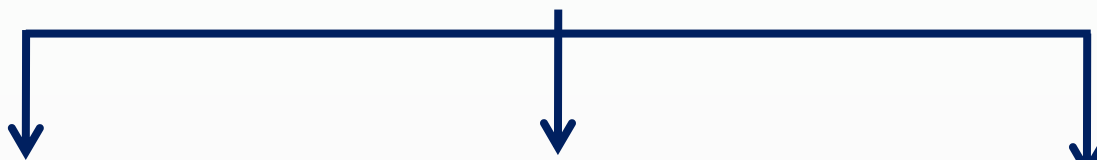

SÉRIE
LOGUS 90



série
sirius70



série
APOLO 5000

Surface Mounting Wiring Devices

3700 Series



47 Series



Waterproof 48 Series



série **QUADRO 45**

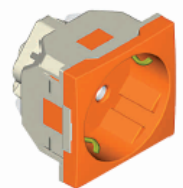
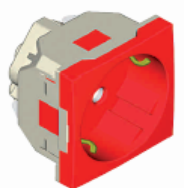
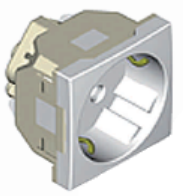
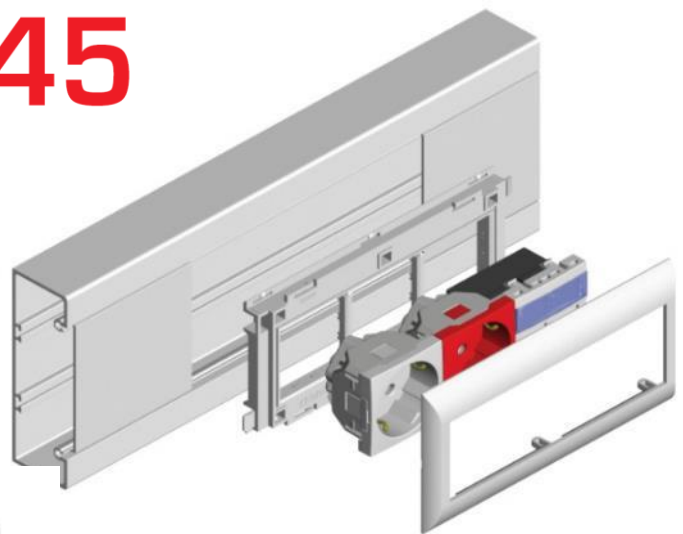
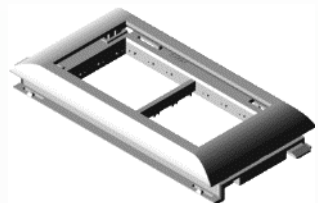
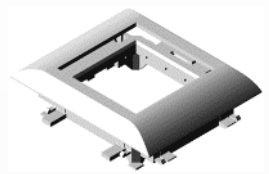

série **QUADRO 45**

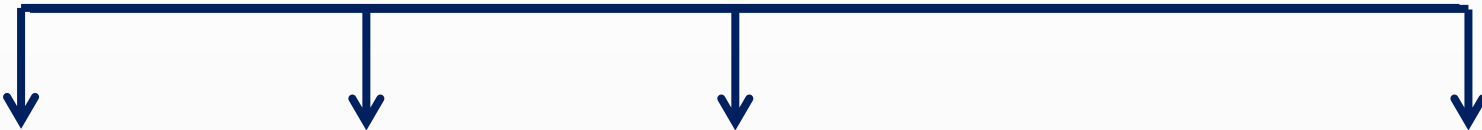

série **QUADRO 45**

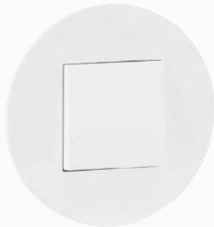

série **QUADRO 45**
de Senho Siza Vieira

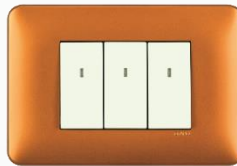

LATINA



Flushed Wiring Devices

Cable Trunkings

Cable Trunkings



- **10 Series** – Trunkings for Electrical and Telecommunications Installations
- **13 Series** – Trunkings for Protecting Cables and Pipes
- **14 Series** – Trunkings for Panelboards

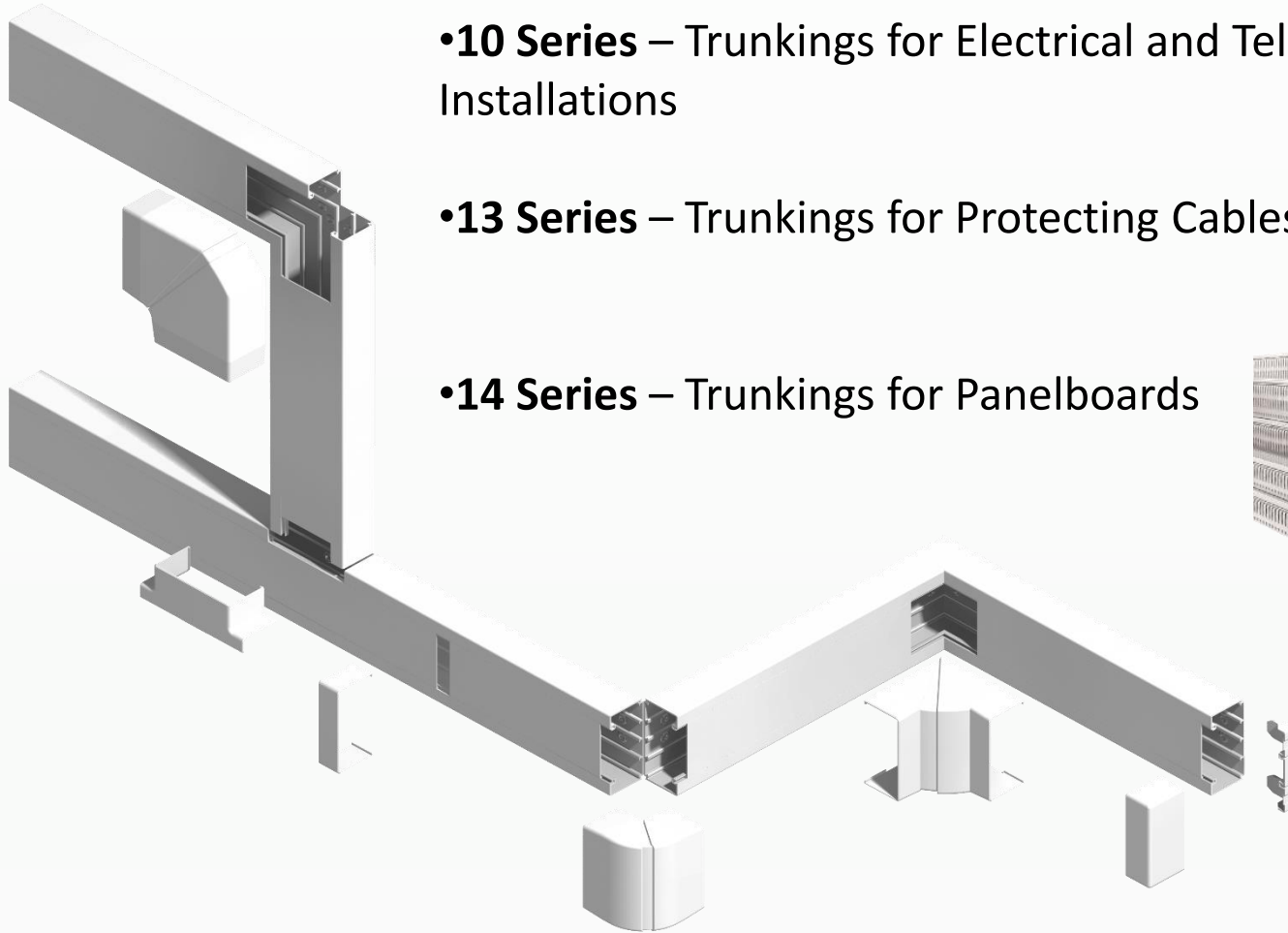

OFFICE SOLUTIONS

Columns & Mini Columns



Floor Boxes



Workstations



..... to be completed with Quadro 45 mechanisms.

OFFICE SOLUTIONS



Electrical & Telecommunication Panelboards

Electrical Panels



Telecommunication Panels



MODUS 55

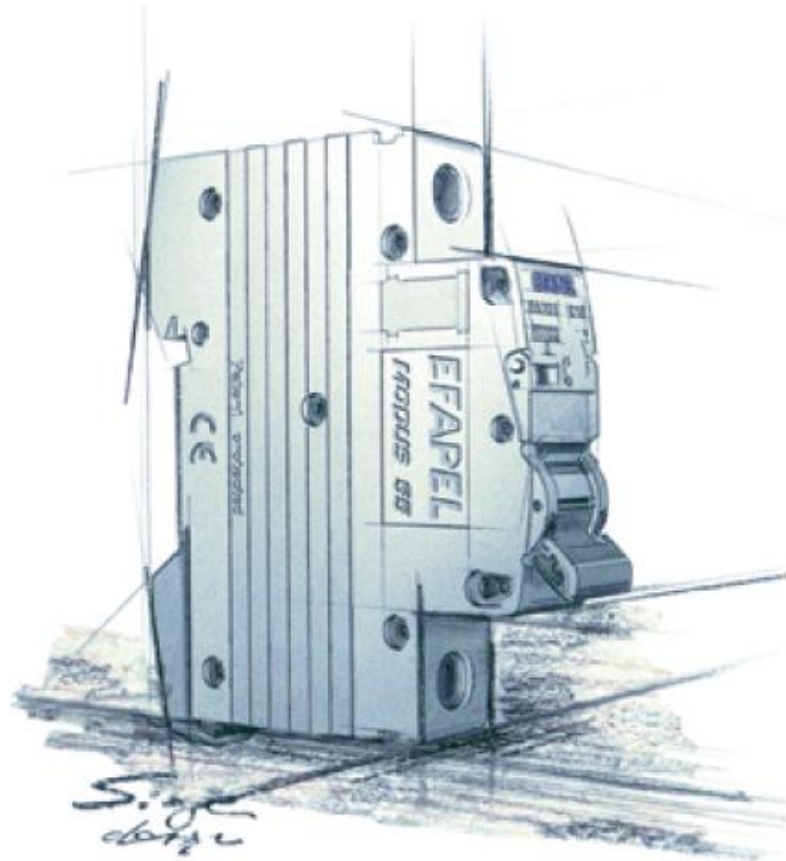

Modular Devices



EFAPEL®

